



FLOW ANGLE PROBE HIGH TEMPERATURE MINIATURE IS® PRESSURE TRANSDUCER

FAP-HT-250 SERIES

- High Frequency, High Accuracy Performance
- Patented Ultra Miniature Rugged Design
- Ideal For Aero Propulsion Measurements and Complex Flow Structures

The FAP-HT-250 design features Kulite's patented SOI leadless technology with sensors positioned at the tip of the probe head. These fast response probes are ideal for aerodynamic measurements with complex flow structures, including turbomachinery flow distortions diffusers/mixers. The 5 position sensor construction allows concurrent measurements of 2 flow angles, total and static pressure, Mach number and flow speed.

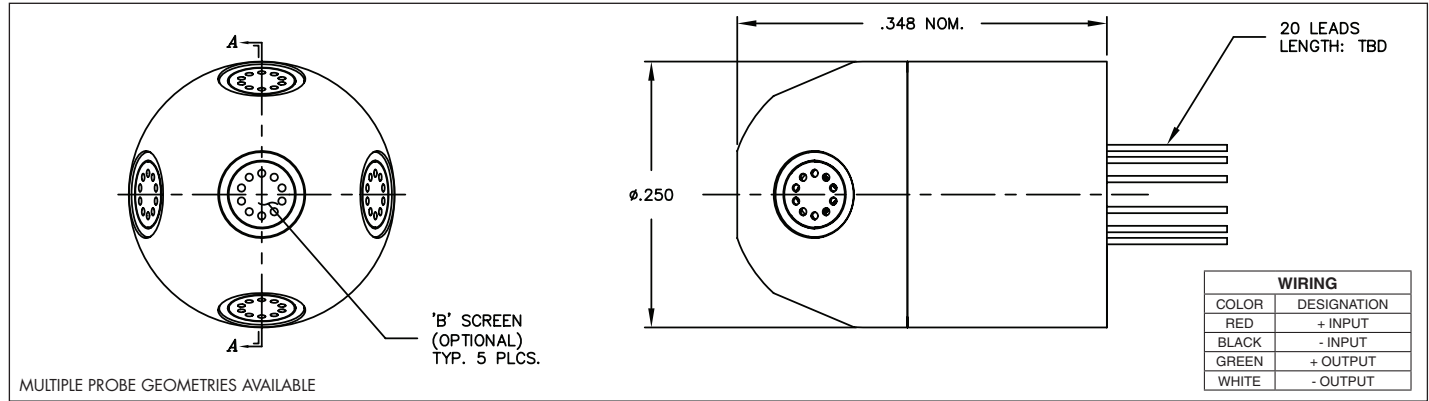

INPUT Pressure Range	1.0 15	1.7 25	3.5 50	7 BAR 100 PSI
Operational Mode	Absolute			
Over Pressure	2 Times Rated Pressure With No Change in Calibration			
Burst Pressure	3 Times Rated Pressure			
Pressure Media	All Nonconductive, Noncorrosive Liquids or Gases (Most Conductive Liquids and Gases - Please Consult Factory)			
Rated Electrical Excitation	10 VDC/AC			
Maximum Electrical Excitation	15 VDC/AC			
Input Impedance	1000 Ohms (Min.)			
OUTPUT Output Impedance	1000 Ohms (Nom.)			
Full Scale Output (FSO)	75 mV (Nom.)	100 mV (Nom.)		
Residual Unbalance	± 5 mV (Typ.)			
Combined Non-Linearity, Hysteresis and Repeatability	± 0.1% FSO BFSL (Typ.), ± 0.5% FSO (Max.)			
Resolution	Infinitesimal			
Natural Frequency (KHz) (Typ.)	200	240	300	380
Acceleration Sensitivity % FS/g Perpendicular Transverse	7.0x10 ⁻⁴ 9.0x10 ⁻⁵	5.0x10 ⁻⁴ 6.0x10 ⁻⁵	3.0x10 ⁻⁴ 4.0x10 ⁻⁵	1.5x10 ⁻⁴ 2.0x10 ⁻⁵
Insulation Resistance	100 Megohm Min. @ 50 VDC			
ENVIRONMENTAL Operating Temperature Range	-65°F to +525°F (-55°C to +273°C)			
Compensated Temperature Range	+80°F to +450°F (+25°C to +235°C)			
Thermal Zero Shift	± 1% FS/100°F (Typ.)			
Thermal Sensitivity Shift	± 1% /100°F (Typ.)			
Steady Acceleration and Linear Vibration	1000g Sine			
PHYSICAL Electrical Connection	4 Leads 36 AWG 36" Long			
Pressure Sensing Principle	Fully Active Four Arm Wheatstone Bridge Dielectrically Isolated Silicon on Silicon Patented Leadless Technology			

Note: Custom pressure ranges, accuracies and mechanical configurations available. Dimensions are in inches. Dimensions in parenthesis are in millimeters. Continuous development and refinement of our products may result in specification changes without notice - all dimensions nominal. (A)

FULLY INTEGRATED MINIATURE, HIGH FREQUENCY FLOW PROBE UTILIZING LEADLESS, SOI TECHNOLOGY SUITABLE FOR GAS TURBINES

Full Paper to Appear in **Proceedings of the ASME Turbo Expo 2011**

Alexander A. Ned, Dr. Tonghuo Shang, Scott Goodman, Adam Hurst, Dr. John Chivers
Kulite Semiconductor Products, Inc.

Dr. Gerald R. Guenette
Massachusetts Institute of Technology

Raymond S. Castner
NASA Glenn Research Center

The measurement of pressure and flow direction have been essential measurements in the development of turbomachines since the very early days of the gas turbine. More recently, these measurements have been used in flow field diagnosis to verify the correct operation of a turbomachine. Over the last three decades there has been a requirement to measure time-varying pressures in turbomachinery applications which have necessitated measurement bandwidths in the order of 100 kHz and the silicon piezoresistive pressure sensor has been the device which has most frequently been used for many of these measurements.

This paper concentrates on the design and application of a 5-hole pressure probe designed for the accurate measurement of unsteady total pressure and flow angle for turbo-machinery applications. Fast response pressure probes have the advantage of offering a high analogue bandwidth, a high signal-to-noise ratio, and a good reliability and robustness as compared to hot-wire techniques for instance. In addition to the magnitude and direction of the flow velocity vector, aerodynamic probes also indicate the total and static pressure as time-resolved quantities. Appropriate data processing then derives not only the steady, but also the periodic and random components of the measured variables.

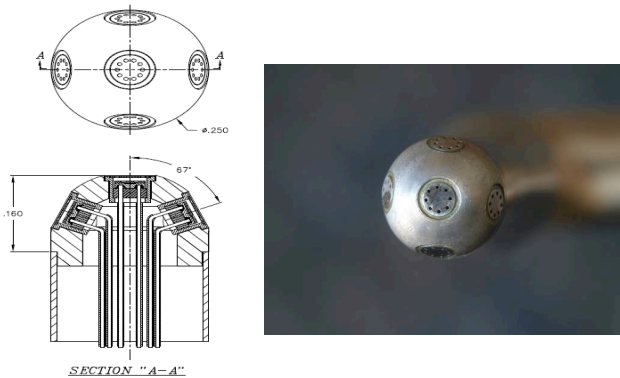

Figure 1: High Temperature 5-Hole Probe

The first generation of the smallest, high frequency 5-hole flow probe was developed and optimized. As part of this development effort, specifically designed, ultra miniature, leadless piezoresistive sensors were fabricated and optimized. The probe hardware and all associated assembly and interconnecting processes were established and optimized. Both static and dynamic testing of the sensors demonstrated excellent

performance characteristics with sensors having a natural frequency above 530 kHz with flat response to 100 kHz.

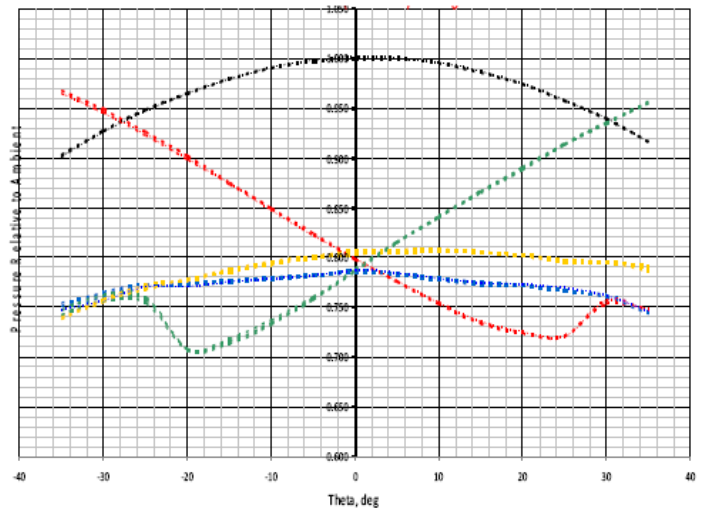

Figure 2: Pressure Reading as Function of Yaw Angle with Elevation Angle of 0 Degrees. Five runs show excellent overlap

Aerodynamic testing performed at MIT provided excellent validation of the five position flow angle probe design. The goal of pressure sensor positioning was to measure pressure variations as a function of flow angle; thus in reverse pressure measurements can be used to deduce flow angle data. Test data obtained at MIT/GTL provided the expected sensor response to flow angle. For instance, the nose sensor's pressure reading drops as it moves away from the incoming flow, whereas the left (or right) sensor's pressure increases as it moves toward the incoming flow.

At early stages of this development effort there were some concerns if small surface discontinuities on the probe's spherical shape can lead to uncertainties to probe performance. Test data shows these concerns are insignificant, because repeated probe performance calibrations demonstrated excellent repeatability and stability in probe performance. The tests also showed excellent flow angle range; probe performance was shown to be stable to a flow angle range of at least +/- 35 degrees, which is the measurement range achievable at test.